

# FLEX Diverter Valve

INNOVATIVE DESIGN AND PLUMBING VERSATILITY

For advanced and trouble-free operation



 **Emaux**  
water technology

Pool & Spa Equipment

# Product Features

## REVOLUTIONARY DESIGN FOR PROFESSIONAL USE

Emaux FLEX diverter valve is a maintenance-free valve with an ergonomic design handle. The PTFE coating gasket gives high reliability and smoothes the turning torque for the valve. A new adjustable dial design offers a simple and flexible inlet selection. The shaft is compatible with actuators made by other manufacturers. When paired with the Emaux FLEX Actuator, it gives the user a reliable automated experience with the valve control.

Valve Material

PVC

Max Operating Pressure

72.5 psi / 5 bar

Max Temperature

50 °C (122 °F )

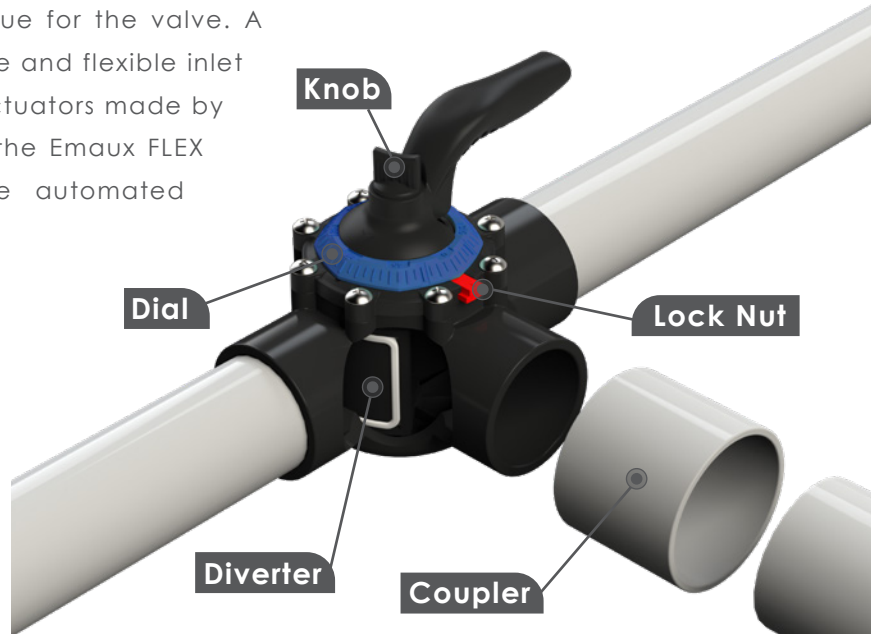

### Advantages:

#### Flexibility and user-friendly

Adjustable dial for instant inlet switching.

#### Maintenance-free

PTFE coating gasket:

- Lubricant-free
- Maintenance-free
- Jam-free

#### Compatibility

Shaft is compatible with other manufacturers' actuators.

#### User experience

Ergonomic design handle promotes comfortable control.

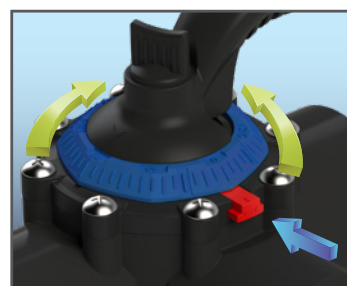

Revolutionary Dial Design

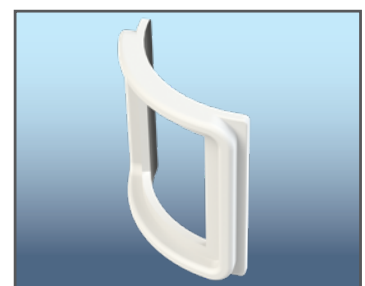

PTFE coating gasket

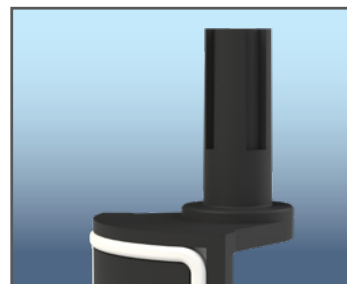

Universal Shaft



Ergonomic design handle

## Product Information:

2-way/3-way diverter valves are available in 1.5" x 2" and 2" x 2.5 sizes for easy use in conjunction with the Emaux FLEX Valve Actuator for automatic operation.

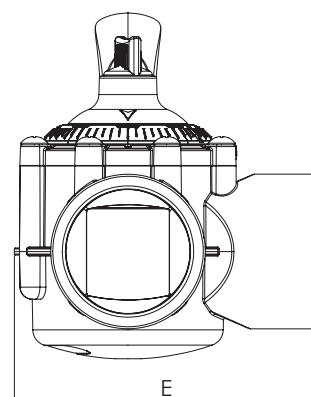
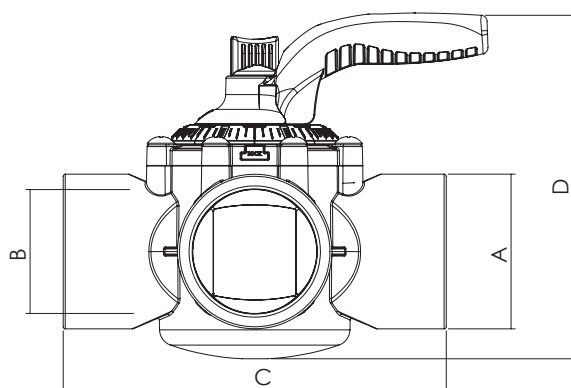

### Three-Way Valve

Code	Model	Material	Connection	A (mm)	B (mm)	C (mm)	D (mm)	E (mm)	Description
91600106	FLEX40-3(A)	PVC	1½" / 2"	Ø60	Ø48	186	168	149	ID 1½" pipe slip in OD 2" coupler
91600108	FLEX50-3(A)	PVC	2" / 2½"	Ø75	Ø60	186	168	149	ID 2" pipe slip in OD 2½" coupler
91600105	FLEX40-3(E)	PVC	GB50 / GB63	Ø63	Ø50	186	168	149	ID GB50 pipe slip in OD GB63 coupler
91600107	FLEX50-3(E)	PVC	GB63 / GB75	Ø75	Ø63	186	168	149	ID GB63 pipe slip in OD GB75 coupler

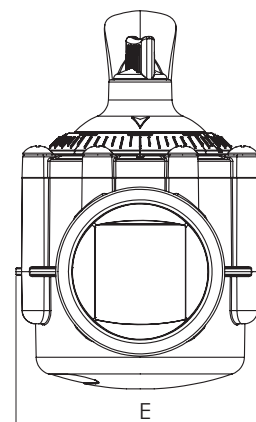
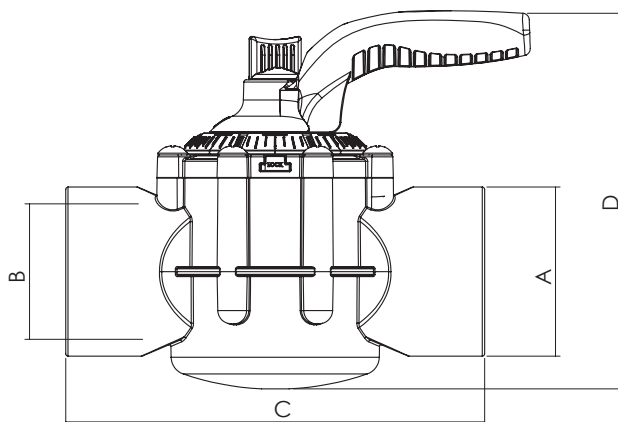

### Two-Way Valve

Code	Model	Material	Connection	A (mm)	B (mm)	C (mm)	D (mm)	E (mm)	Description
91600006	FLEX40-2(A)	PVC	1½" / 2"	Ø60	Ø48	186	168	110	ID 1½" pipe slip in OD 2" coupler
91600008	FLEX50-2(A)	PVC	2" / 2½"	Ø75	Ø60	186	168	110	ID 2" pipe slip in OD 2½" coupler
91600005	FLEX40-2(E)	PVC	GB50 / GB63	Ø63	Ø50	186	168	110	ID GB50 pipe slip in OD GB63 coupler
91600007	FLEX50-2(E)	PVC	GB63 / GB75	Ø75	Ø63	186	168	110	ID GB63 pipe slip in OD GB75 coupler

## EMAUX WATER TECHNOLOGY CO., LTD

ADDRESS: Flat A-D, 20/F., Kai Bo 22, 22 Wing Kin Road,  
Kwai Chung, HK

PHONE +852 2832 9880

[www.emauxgroup.com](http://www.emauxgroup.com)

 **YOUR PREMIER SUPPLIER**

Available from:

ALL SPECIFICATIONS ARE SUBJECT TO CHANGE WITHOUT NOTICE.  
© EMAUX WATER TECHNOLOGY CO., LTD. ALL RIGHTS RESERVED.

[www.emauxgroup.com](http://www.emauxgroup.com)