

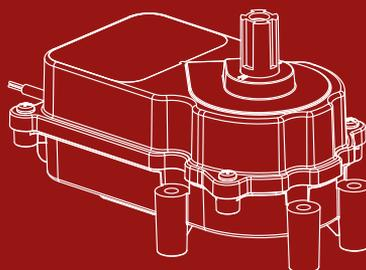

FLEX VALVE ACTUATOR

Installation and Operation manual



USER MANUAL

Model: FLEX Series

TABLE OF CONTENTS

PAGE	
2 WARNINGS AND SAFETY INSTRUCTIONS
2 1. PRODUCT INTRODUCTION
2 2. SPECIFICATIONS
2 2.1 DIMENSION
3 3. INSTALLATION & OPERATION
4 3.1 BASIC CAM SETTING
5 3.2 MOUNTING INSTRUCTIONS
5 3.3 TOGGLE SWITCH
5 3.4 ADVANCED CAM SETTING
6 3.5 SYNCHRONIZATION
6 3.6 MANUAL OVERRIDE (MO)
7 4. MAINTENANCE
7 5. WIRING DIAGRAMS
9 6. TROUBLESHOOTING
10 7. SPARE PARTS LIST
11 8. TERMS OF THE WARRANTY



WARNING

This product should be installed and repaired by a technician who is qualified in the installation and maintenance of pool/spa products. Please read this manual before installing the product. The instructions in this manual can be followed exactly. Disconnect electrical power before removing the cover for servicing unit. Replace all screws and covers before reconnecting the unit to electric power. Incorrect installation and/or operation can cause serious injury, property damage, or death. To reduce the risk of injury, do not permit children to use this product. Improper installation and/or operation will void the warranty.

1. PRODUCT INTRODUCTION

Emaux FLEX Valve Actuator is a universal actuator which can work with most major manufactures' automatic controls and valves, operating on 2-way and 3-way valves. Adjustable cams give high flexibility for accurate position. Slim design with corrosion-proof casing, When paired for use with new Emaux 2-way and 3-way valves ,it provides the user with reliable automation over valve control.

2. SPECIFICATIONS

Code	Model	Material	Voltage	Cycles	Wire	Cable Length
91609013	FLEX-ACT	PC	24V AC	50/60 Hz	3 - conductor Black (Common) Red (Switch Leg) White (Switch Leg)	6m (18ft)

2.1 Dimension

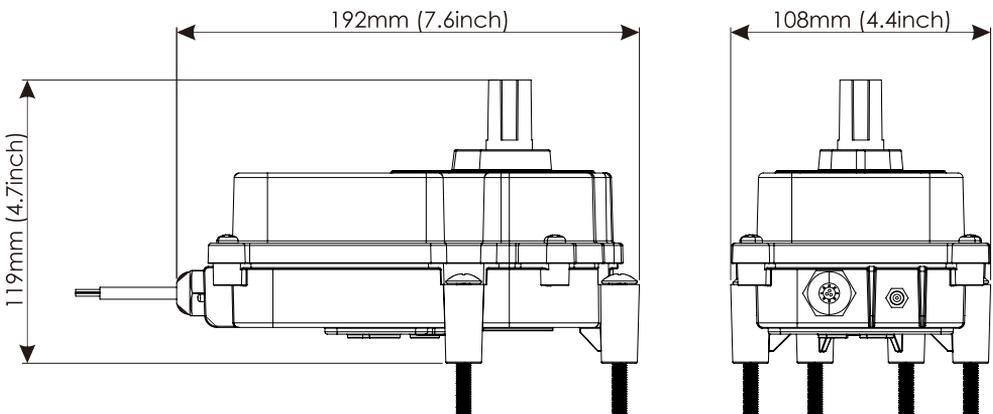

3. INSTALLATION & OPERATION

There are 4 different positions for mounting the Valve Actuator to the **3-way valve**. The cam settings may have to be changed depending on the location of the inlet port (the port where water enters).

NOTE:

The Arrows → are showing which screws required to change to long screws.

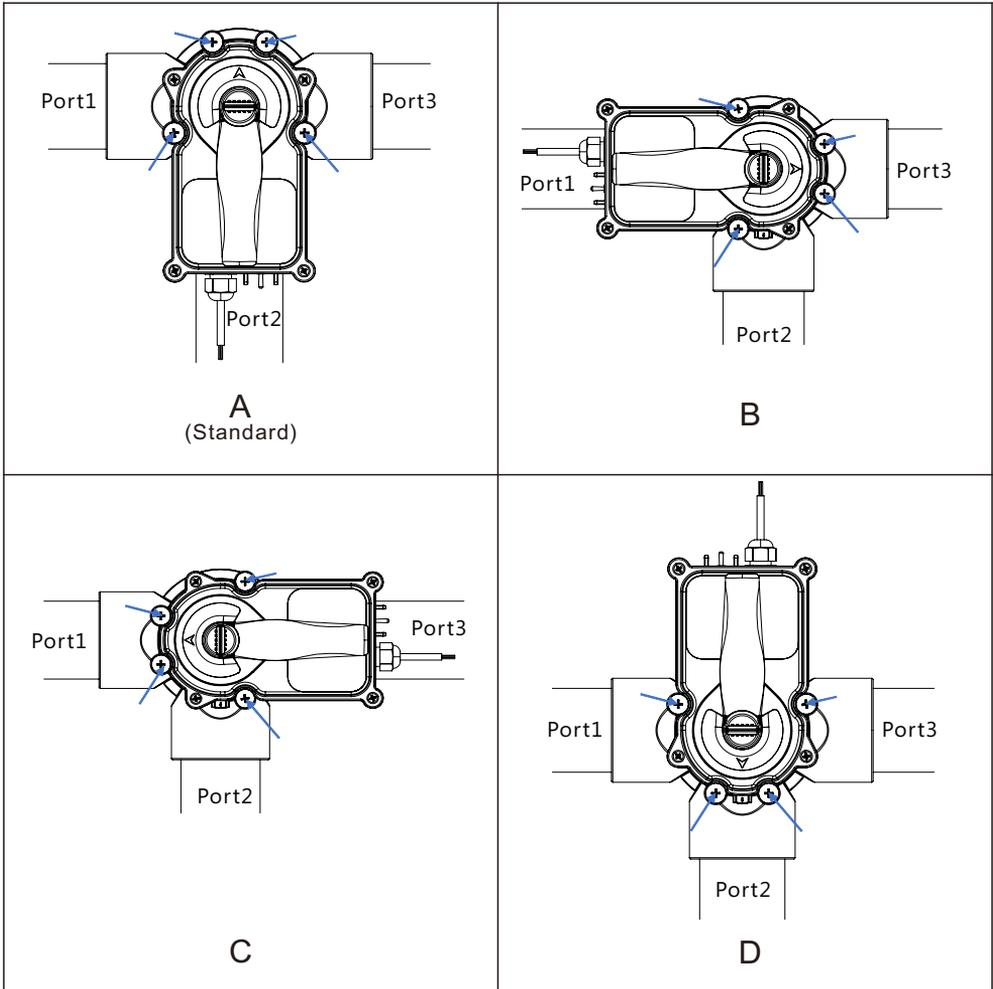

Fig. 1 4 different positions of mounting the Valve Actuator to the **3-way valve**.

3.1 Basic cam setting

Test your Actuator

a. Default

- Both upper and lower CAM are pointing to the "12 o'clock"

b. If you need to make adjustment

- Connect your actuator to control system
- Use manual mode to test arrow position
- Refer to 3.3 and 3.4 to adjust.

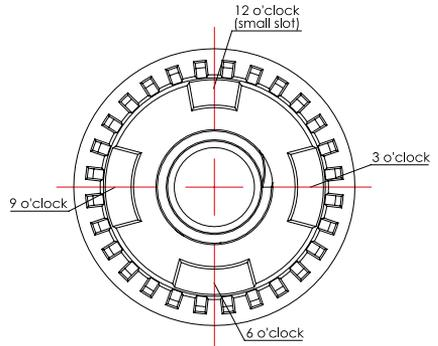

Fig. 2

(3-way valve)

Use the chart to determine the correct basic cam setting by using standard clock positions. The chart below shows the cam settings for 3-way valves.

Mounting option	Inlet (Water enters port)	Basic Cam Setting		Port Where Water Exits	
		UPPER CAM	LOWER CAM	Port	Port
A (standard)	1	9 o'clock	6 o'clock	2	3
	2 (standard)	12 o'clock	12 o'clock	1	3
	3	6 o'clock	3 o'clock	1	2
B	1	12 o'clock	9 o'clock	2	3
	2	3 o'clock	3 o'clock	1	3
	3	9 o'clock	6 o'clock	1	2
C	1	6 o'clock	3 o'clock	2	3
	2	9 o'clock	9 o'clock	1	3
	3	3 o'clock	12 o'clock	1	2
D	1	3 o'clock	12 o'clock	2	3
	2	6 o'clock	6 o'clock	1	3
	3	12 o'clock	9 o'clock	1	2

(2-way valve)

For the actuators mounted on 2-way valves, the cam settings are the same in all cases. The chart shows the cam settings for 2-way valves.

Basic Cam Setting	
UPPER CAM	LOWER CAM
3 o'clock	6 o'clock

3.2 Mounting Instructions

Procedure:

1. Remove the knob and handle from the valve
2. Refer to **Fig.1** to determine which four screws to remove.
3. Place the valve handle on the actuator shaft and tighten the knob.
4. Align the smallest tooth on the actuator shaft with the smallest slot on the valve diverter.
5. With the two shafts engaged, rotate the actuator until the holes on the actuator align with the screw holes on the cover.
6. Using the 4 long screws (M6x55) provided to secure it in place. **Do not over-tighten.**



Fig. 3

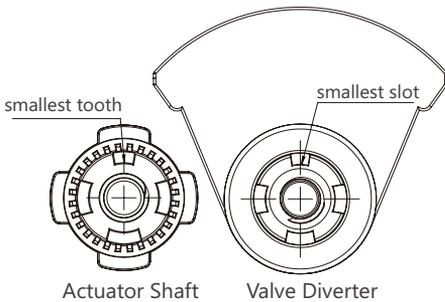

Note:

Factory default is matched with standard mount. If the valve is connected in a standard installation, there is no need to perform a cam adjustment.

3.3 Toggle Switch

- ON1 - Diverter rotate counter clockwise
- OFF - Stop
- ON2 - Diverter rotate - clockwise

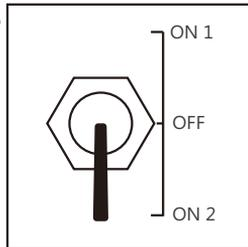

Fig. 4

3.4 Advanced Cam Setting

1. Move the toggle switch to OFF (Centre) position.
2. Remove the knob and the handle from the actuator shaft.
3. Remove four screws on the actuator and open the cover.
4. The cams are located under the cover bushing and on the actuator shaft. Slide the cams off the shaft splines and rotate them to the desired position. Refer to the chart in Basic Cam Settings for determining the position of the cam.

5. For advanced cam settings, the design of the shaft has been divided into 28 directions to customize water flow for your installation. Each of them is around 13 degrees from the other. Users may select partial open, semi-open, partial close, etc.). These settings are not listed in the chart. The 12 o'clock (small slot) is always the reference of every setting (Fig. 2). The upper cam affects the clockwise position stop point. The lower cam affects the counter-clockwise rotation stop point.
6. The toggle switch on the bottom of the valve actuator can be used to verify if the new adjustment is correct (switch between ON1 and ON2).
7. Replace cover and handle and tighten screws and the locking knob.
8. Put the toggle switch back to ON1 or ON2 position.

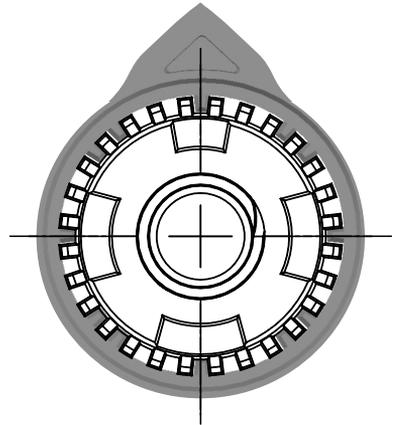

Fig. 5

Note:

Advanced cam setting should be performed by pool technician.

3.5 Synchronization

A typical pool with a spa might have 3-6 diverter valves to control the flow of water through the pool and spa. If one is rotating in the opposite direction to the other, the actuators have to be adjusted to bring them into Sync. Simply flip the toggle switch of the Actuator between ON1 and ON2.

3.6 Manual Override (MO)



CAUTION

Turn power OFF to all filtration pumps before doing this action, to minimize the possibility of any injury or damage.

The valve position may have to be adjusted manually when necessary. This happens when the controller is not accessible or following a power failure. Follow the instructions below.

1. Turn the toggle switch to the OFF position.
2. Unscrew anti clockwise the knob for 1 turn approximately.
3. Push down the handle and knob. This will disengage the gear train and allow the handle, thus the diverter, to move to any position.
4. Make sure to turn the actuator to the automatic position after manual override. Turn clockwise or counter clockwise slightly until you feel the shaft slide up into the gear train. Then, turn the knob clockwise to lock the handle.
5. Tighten the knob.
6. Flip toggle switch back to the original position.

4. MAINTENANCE

The FLEX Valve Actuator has 2 seals which require lubrication once a year. These seals are located at the top and bottom of the actuator, where the shaft exits the actuator housing. Please follow the steps to lubricate those seals:

1. Turn the actuator power OFF.
2. Remove the knob and the handle.
3. Spread a small amount of silicone base lubricant around the actuator shaft where it enters the cover (See Fig. 6).
4. Reinstall the handle and knob, do not over-tighten.
5. Push down on the knob and handle to force the actuator into manual override.
6. Spread a small amount of lubricant around the actuator shaft where it protrudes from the bottom of the actuator.
7. Turn the handle once around to spread the lubricant.
8. Pull up on the handle and let it click into place.
9. Tighten the knob.



Fig. 6

5. WIRING DIAGRAMS



WARNING

To avoid electric shock which can result in property damage, severe injury or death, disconnect power to the system at the main circuit breaker before servicing.

To minimize the risk of injury and avoid damage to the equipment, use a properly sized, listed Class 2 transformer for connection to the power supply.

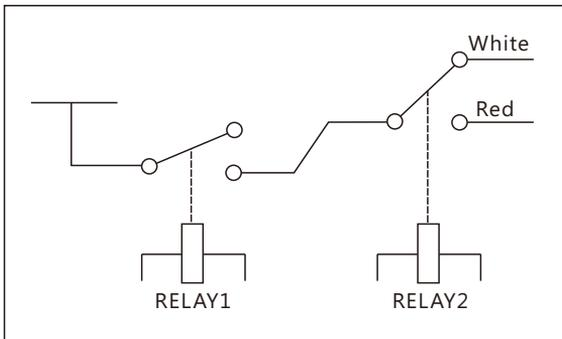

Relay1: Voltage connect control
Relay2: Turn control

In the following image, you can see how the connection of the 2 actuators would be. For each connected actuator, the amperage will rise by about 1A and the fuse will have to be modified.

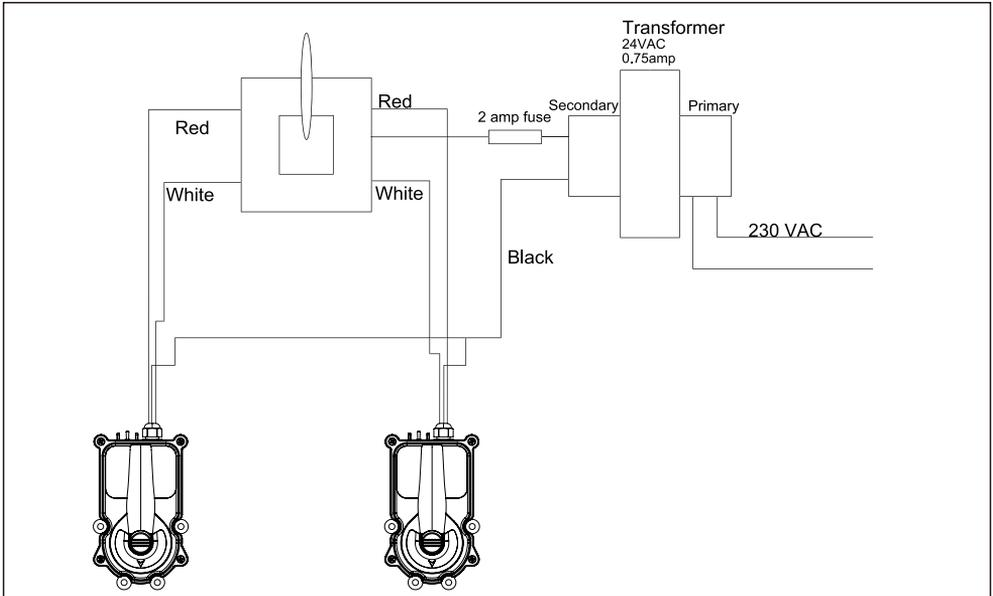

The internal circuit of the actuator is based on a motor that turns the valve, 2 limit switches, to know the 2 stop positions, a capacitor, for possible peaks in the line, and a switch controlling the tension of the red wire (turn one way) or white wire (turn the other way).

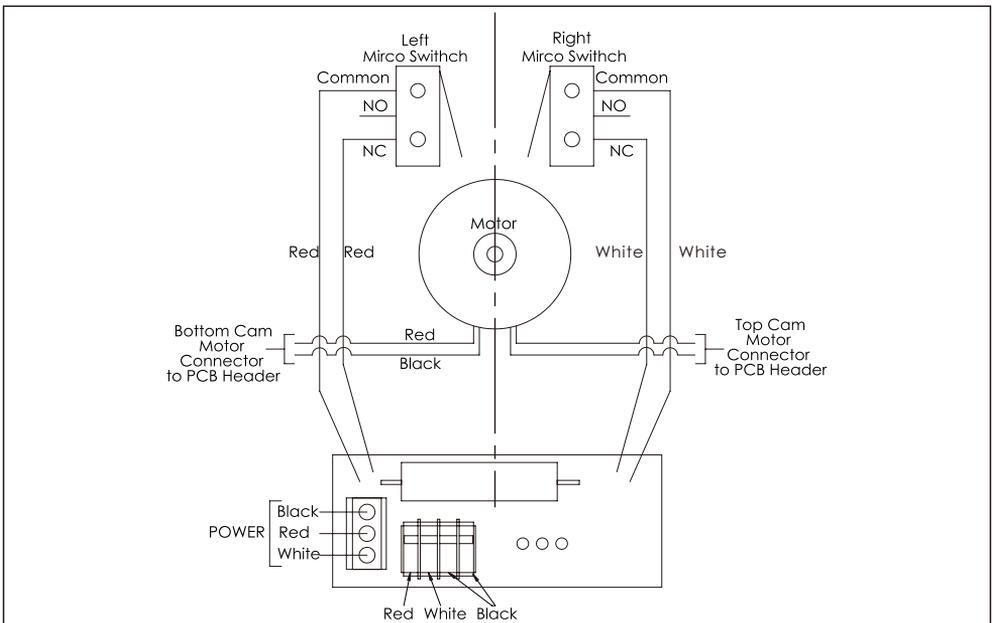

6. TROUBLESHOOTING

Problem	Cause	Solution
The actuator handle oscillates.	Lack of valve seal lubrication. Obstruction in the valve body	Lubricate valve. See the "Maintenance" section.
The actuator motor works but the valve diverter does not turn.	The actuator shaft has broken.	Replace the actuator shaft.
	Actuator in manual position.	Pull up on the handle while rotating.
	The gear train was damaged.	Replace gear or shaft.
The actuator motor does not turn.	No power to the actuator.	Check voltage between black (common) wire and each switch leg (red, white)
	Toggle switch in the OFF position.	Flip toggle switch to ON 1 or ON 2 positions.
	The motor has failed.	Replace motor.
	Failed or broken microswitch.	Replace microswitch.
	Both cams are in contact with their microswitches.	Check the cam setting section.
The actuator rotates in one direction but not back again.	Broken or damaged microswitch.	Replace microswitch.
	Bad connection(s).	Check all connections.
	Bad control relay switch.	At the power source check the operation of the control relay or switch.
	Broken wire.	Check red and white wires.
Water inside the valve actuator	Damaged seals.	Replace seals.

7. SPARE PART LIST

Key No.	Part No.	Description	Qty
1	112010166	M5 x 15 Screw	4
2	57200003	Housing Cover	1
3	111000053	Cover O-ring	1
4	57200005	Lock Plate	1
5	E042810	M3.5 x 7 Screw	1
6	57200006	Cover Bushing	1
7	57200007	Cam	2
8	111040083	Gasket	1
9	E042811	Motor Synchronous (with M4 x 8 screws [2] and washers [2])	1
10	E042812	Micro Switch Assembly (With M2.3 x 10 screw)	1
11	57200008	Switch Nest	2
12	E042813	Circuit Board (with M4 x 12 screws)	1
13	03011364	M4 x 12 Screw	5
14	57200001	Plate	1
15	57200009	Shaft	1
16	E042814	Pivot (3)	1
17	E042815	Gear Set (4)	1
18	57200002	Spacer	1
19	112010168	M6 x 52 Screw	4
20	57200004	Housing	1
21	106234778	Cable module	1
22	112060025	Spring	1



8. TERMS OF THE WARRANTY

As original purchaser of this equipment have purchased from Emaux Water Technology Co Ltd, through Authorized International Distributor or Dealer, warrants its products free from defects in materials and workmanship under normal use during warranty period. The warranty period begins on the day of purchase and extends only to the original purchaser. It is not transferable to anyone who subsequently purchases the product from you. It excludes all expendable parts.

During the warranty period, Emaux authorized reseller will repair or replace defective parts with new parts or, at the option of Emaux, serviceable used parts that are equivalent or superior to new parts in performance.

This Limited Warranty extends only to products purchased from Emaux authorized reseller. This Limited Warranty does not extend to any product that has been damaged or rendered defective

- (a) as a result of accident, misuse or abuse;
- (b) as a result of an act of God;
- (c) by operation outside the usage parameters stated herein;
- (d) by the use of parts not manufactured or sold by Emaux;
- (e) by modification of the product;
- (f) as a result of war or terrorist attack; or
- (g) as a result of service by anyone other than Emaux authorized reseller or authorized agent.

EXCEPT AS EXPRESSLY SET FORTH IN THIS WARRANTY, EMAUX MAKES NO OTHER WARRANTIES EXPRESSED OR IMPLIED, INCLUDING ANY IMPLIED WARRANTIES OR MERCHANTABILITY AND FITNESS FOR A PARTICULAR PURPOSE. EMAUX EXPRESSLY DISCLAIMS ALL WARRANTIES NOT STATED IN THIS LIMITED WARRANTY. ANY IMPLIED WARRANTIES THAT MAY BE IMPOSED BY LAW ARE LIMITED TO THE TERMS OF THIS EXPRESS LIMITED WARRANTY.

EMAUX WATER TECHNOLOGY CO., LTD

ADDRESS FLAT A-D, 20/F., KAI BO 22, 22 WING KIN ROAD,
KWAI CHUNG, HONG KONG
PHONE +852 2832 9880

 **YOUR PREMIER SUPPLIER**

www.emauxgroup.com